

1、 DIMENSION DIAGRAM (Unit: mm)

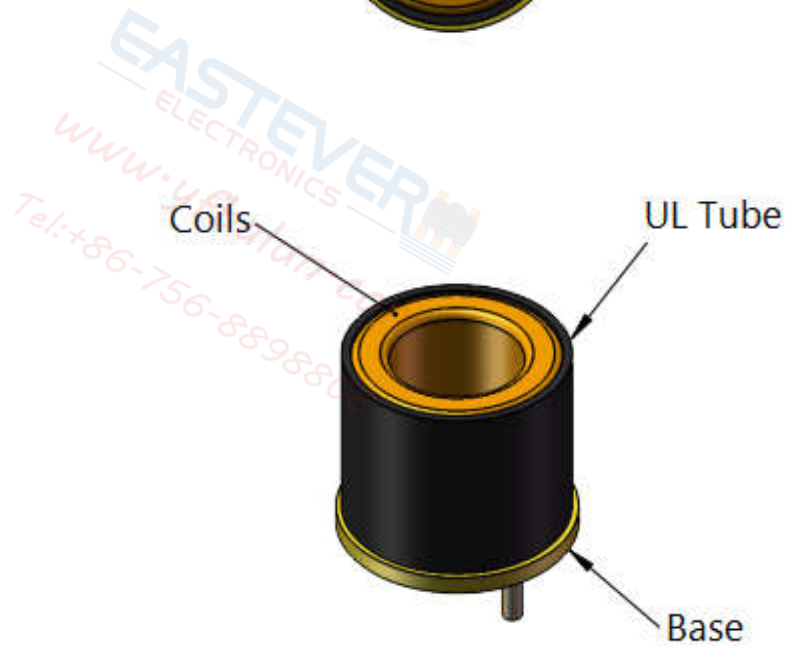

2、 Electrical Structure :

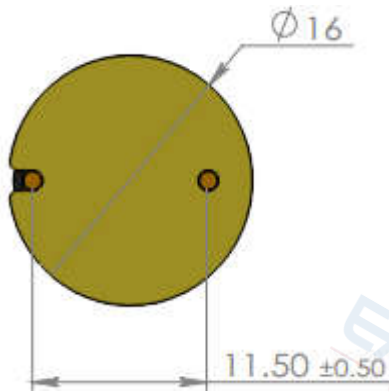
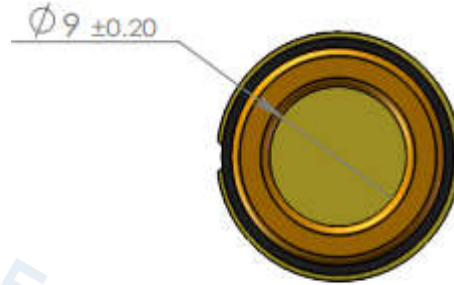
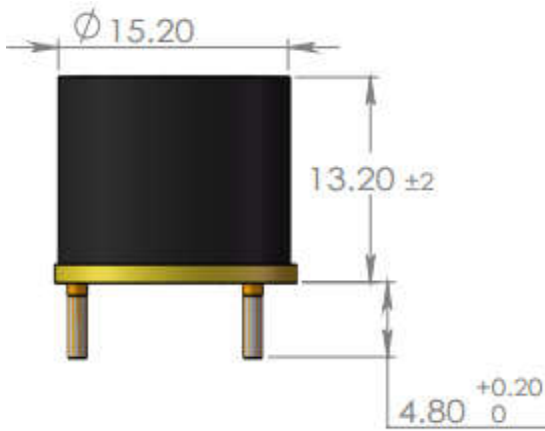
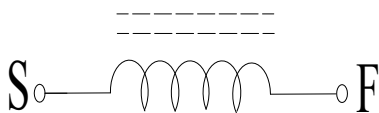

3、 Electrical Requirements:

- Wire : EIW-1.20
- Inductance : 4.0uH±20%
- Rated Current: 7.0A Max
- DCR : 30.0mΩ Max
- Test Frequency: 1KHz/0.3V
- Operating temperature range : -40℃ to +85℃
- Storage temperature range : -55℃ to +100℃

DRAW BY

yang lin

CHECKED BY

ye yong jun

APPROVED BY

deng gao